

How to Convert Any 6-Volt Vehicle to 12-Volt

With Step-by-Step Installation Instructions

Vintage Auto Garage

*Best in Class Products
for American Classics*



Written by Jay Johnson

Copy written, all rights reserved, June 2023

No part of this booklet may be reproduced without the written permission from Vintage Auto Garage LLC.

Vintage Auto Garage LLC

11040 Bollinger Canyon Rd

Suite 186

San Ramon Ca 94582

800-516-4461

www.vintageautogarage.com

SAFETY ALERT: Use caution when working around your vehicle; rotating belts and pulleys are hazardous and can catch clothing and take off fingers. Always disconnect the battery when doing any electrical work, which will avoid shock hazard and burns. Use jack stands when working under vehicle. Follow instructions and use common sense and be SAFE!

Brief review of electricity

The following will help you better understand what is involved in converting any vehicle from 6 to 12 volts

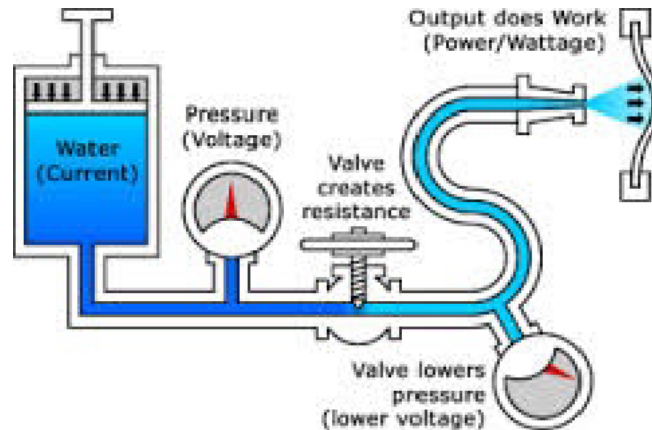

First, let's review how electricity works.

Referring to the diagram above which depicts a simple way to think of electricity like water. Example, in the diagram the water tank would act like the battery providing pressure and volume, the hose would be the electrical wiring, the water valve similar to the resistors, and the nozzle is the output power or wattage required to power a device like a motor.

With this understanding, when increasing the capacity or volume of the water tank the pressure needed to drive a device is reduced. This water analogy is similar to changing from 6 to 12 volts. When doubling the voltage (increase the water tank size) the amperage or pressure needed to drive an electric device drops. Example, a heater motor that requires 20 amps on 6 volts will only require 10 amps at 12 volts, so half the effort or amperage when increasing the voltage.

The wiring is similar to the size of the water hose, requiring twice the size or gauge of wire on 6 volts versus 12 volts. So you can see, vehicles with 6 volt wiring use double the gauge or size of wire that the 12 volt counterpart will need. All this means if the vehicles 6 volt wiring is not frayed or causing

possible shorts can be used in 12 volt systems. Same goes for all the 6 volt switches, all can be used in 12 volt electrical systems. The exception is the headlight switch that will need a relay and will cover this later on.

Electrical terms to serve as a guide

AC Alternating current

Amps: Volume of electricity

Capacitor: Device that stores electricity for short periods of time (not voltage sensitive)

DC Direct current

Diode: Allows current to flow in one direction only.

Parallel: Wired similar to home lighting system, each light powered individually.

Polarity: Defines the direction current flows

Resistor: Device that controls the volume of electricity, acts like a hose nozzle

Series Wiring: Similar to a string of old Christmas tree lights, one bulb goes out, they all go out.

Volts: Pressure of electricity

Watts: Amount of electricity used or needed to power a device

To calculate watts to amps use this [calculator](#). Will help if you know the amperage needed if you know the wattage for say a sound system.

Before starting your conversion, a word about safety:

You can become injured working around electricity, you may not think 6 or 12 volts can harm you but it can. A battery can pull endless current for a short period of time and if you get between the positive and negative side of the battery and the situation is right, you can get badly burned. Any time working around your vehicle's electrical system, ***always disconnect the negative battery terminal*** and be careful when removing the terminals. Also be careful when working around **belts and pulleys**, these can catch clothing, fingers, and hair. OK enough said.... **just be safe.**

Positive versus negative-grounded electrical systems:

Ford, Dodge, Chrysler, Plymouth, DeSoto, Studebaker, Cadillac, Kaiser, and a few other brands wired their early automobiles with the positive terminal of the battery to ground, or the frame, and the negative battery to the starter and electrical system. Chevrolet and most GM vehicles (except Cadillac) wired their vehicles with negative grounds.

After the late 50s early 60s, most every manufacture went to negative-grounded electrical systems and is the standard today. All modern solid-state electronics, radios, phone chargers and solid-state voltage reducers are based on negative grounded systems and will become damaged if connected to a positive ground system.

When performing the conversion to 12 volts, if your vehicle is positive ground, you will want to switch your systems to negative ground by simply changing the terminals on the battery. The negative pole of the battery to the chassis and engine and the positive going directly to the starter or starter solenoid and electrical system.

When switching polarity from positive to negative ground everything in the vehicle will work as it did before. Hopefully this should remove the myth about starters and heater motors turning backwards when changing polari-

ty. *They will all turn in the correct direction.* The reason is that starter and heater motors in all early vehicle do not use permanent magnet motors, Instead they use field coils to energize and create the magnetic force and these field coil type motors are designed to turn in one direction only, regardless of polarity.

Generator versus alternators

You have the option either to convert your generator to 12 volts or install a modern alternator with built-in voltage regulator.

Staying with a generator and converting to 12 volts has limitations on output amperage. The most a 12-volt generator will produce is 40-42 amps, and this greatly depends on the condition of the armature. Perhaps the bigger disadvantage of a generator is the inability for the generator to produce current at low engine speeds. You need to be driving at 20 MPH or so before the old generator starts to produce any current at all. This means at idle speed the electrical system is running off the battery and is the main reason why the engine is hard to start after driving short distances because the battery has not had sufficient time to recharge.

Alternators were designed in the late 1960s, early 1970s, to meet the higher electrical demands of the automobile. Alternators work different from generators by spinning the field coils inside stationary coils of wire called stators, this is opposite from the way a generator works. By changing the design, the alternator can turn much faster, up to 10,000 RPM, before there is any internal damage. Therefore, most alternators are driven at 1.5 to 2 times engine speed. This higher speed ensures a strong current output. Modern engines designed the pulley system and ratios to turn the alternator fast enough to produce the desired output at low and high speeds. However older engines typically have lower idle RPM than the modern counterpart and the pulley ratios were meant for generators that had RPM restrictions, keep this in mind when selecting the correct alternator output amperage. [See different alternators](#)

1-wire vs. 2-wire alternators

The 1-wire alternator means there is only one connection required to connect the alternator into the electrical system. 1-wire alternators utilize residual magnetism stored inside the rotor to excite the field coils and allows the alternator to start charging when it reaches its turn on speed. These are fine for modern engine applications with pulley ratios that turn the alternator fast enough at idle and are driven regularly. 1-wire alternators are not always the best solution for older, slower-idling engines that might sit for several months between running.

The 2-wire alternator utilizes an extra connection called an excite wire that connects to the alternator internal regulator delivering a small amount of 12-volt current that starts the alternator charging and will remain charging and does not rely on residual magnetism to start the charging process.

2-wire alternator also have the ability to operate a dash charge-no-charge light. See wire diagram with dash light wired below.

Wiring diagram for Delco Series 10-SI and Series 12-SI alternators

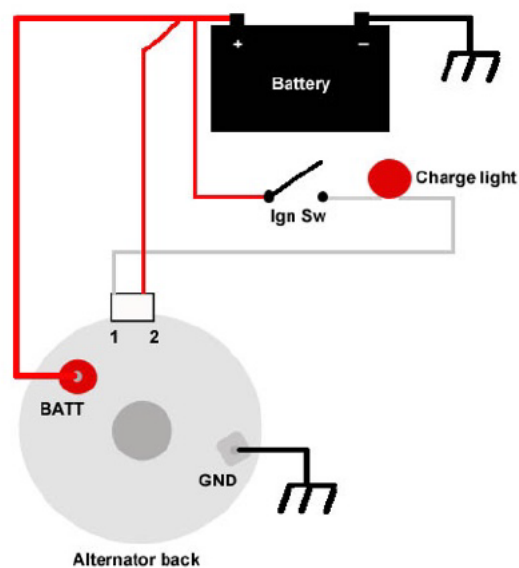





To connect the 2-wire alternator, there is an excite plug that snaps into the rear of the alternator and commonly located under a black dust cover. Re-

move this dust cover and insert the excite plug. The plug comes with a long white wire that connects to switched 12 volts. Connect this white wire to the ignition switch or connect to the plus side of the coil, (which is the same electrical connection as the key switch). On Delco 10 and 12SI alternators, there is short red wire that connects to the output of the alternator to sense the output voltage. This short red wire does not exist on the later model CS130 alternators. (see the 2 types below) [see different excite plugs](#)

The white excite wire should have a diode (one-way electrical check valve) to allow current to flow *into the alternator*. Without this diode, and particularly on early vehicles, ignition switches without a neutral will prevent engine shutdown and possible drain the battery overnight. The other second connection is the large output wire that goes directly to the positive side of the battery via a fuse or fuse-able link. (in a negative ground system.

Below are the two different alternators with the connection wire and plug.

	<p>10 and 12 SI alternators show 2-wire alternator connection. The white wire is the one with the diode and connects to switched 12 volts. Short red wire connects to alt output and the Long Red 10 AWG wire goes directly to the battery positive side.</p>	
	<p>CS130 Shows 2-wire alternator connection shows the white wire with the diode and connects to switched 12 volts. Long Red 10 AWG wire connects directly to the battery positive side. Note there is no short red sense wire needed; it is internal to the alternator.</p>	

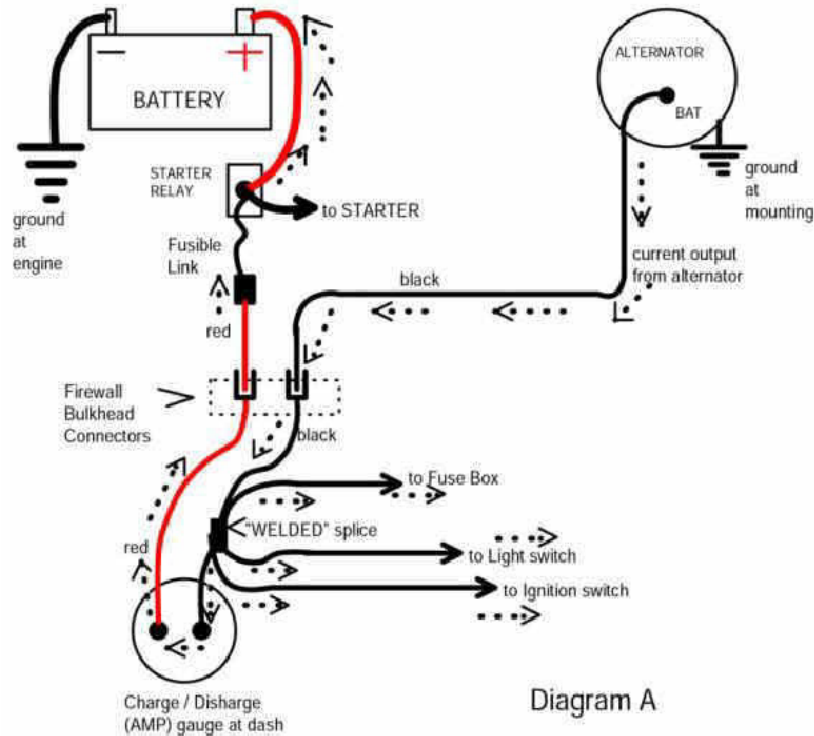

Diagram A will help you connect the alternator to the battery via a dash ammeter. Be certain to connect the alternator to the battery with correct-size, automotive-approved wire and fuse. Note: the alternator is connected to the battery 100% of the time, this is why a fuse is recommended to keep vehicle safe in case of shorts.

Fuses wiring and circuit breakers

Most older vehicles only have a few circuit breakers under the dash and very few fuses if any. These old breakers will work on 12 volts but don't provide the electrical protection that modern automotive fuses provide. If the vehicle is in need of new wiring there are many great aftermarket wiring harnesses with automotive approved wiring and fuse panels. Choose the correct size wiring harness for your vehicle.

Ammeters / Battery gauges.

If you plan to keep your original ammeter/battery gauge in place, there is no need to install a reducer. Ammeters read current flow and not voltage. If you have a volt meter rather than ammeter, you may need to add a resistor, or add an aftermarket [12-volt meter](#).

Ammeters read current back and forth between the battery and the alternator, if you install a 100-amp alternator does not mean that 100 amps is being used; the demand on the alternator is dictated by the demand of the electrical system. In other words, if the electrical system demand is 50 amps with everything turned on, that is all the alternator internal regulator will produce.

It is not recommended to use the original ammeter or battery gauge in a high demand electrical system, these older meters were meant for 6 volts and 30-40 amps draw. Above this can damage these meters, best to bypass in high demand electrical systems and install 12 volt under dash volt meter. If you do use the existing dash meter in the conversion, just know the gauge will not be all that accurate on 12 volts as it was calibrated to operate at lower voltage higher amps.

How to figure the correct alternator output for your vehicle.

An important aspect in selecting alternator output is the demand your vehicle will have at low and high RPM. Most vehicles with ignition, running lights, heater motor, and a radio will work great on 80-100-amp alternator; add a radiator cooling fan, AC, stereo and air-ride now you must have a much higher amperage alternator, 160-175-amps. Use the the following to help determine alternator output. 100 amp = 40- 50 amps at idle, 160 amp= 50-70 amps at idle, and 175 = 90-110 amps at idle. As you can see, the higher the output alternator, the higher idle output. Essentially not much of an issues with output at the higher RPM levels, mostly concerned around the lower speed and idle RPM so the vehicle is not running off the battery when at idle.

Alternator pulleys

Pulleys come in different belt widths and diameters. Choose the pulley that will fit the current vehicle belt size by measuring the top of the exiting generator belt. Typical belt sizes are 3/8", 1/2", 5/8", and 3/4". You want to avoid using the pulley from the old generator because it is too large in diameter and will not turn the alternator fast enough at low idle speeds. Ideally, the alternator should turn 2.5 to 3 times faster than the crank pulley; this is not always possible with older engines, which could be 2 to 1. The faster the alternator turns at idle, the better output current the alternator will produce. With engines that idle in the 600-800 RPM range and 2-1 ratio the alternator will be turning at 1200-1600 RPM which may be right at the alternator turn on speed which is around 1400 RPM depending on the alternator and how it is made.

6 volt Alternators

For the car/truck owner that wants to keep a 6 volt system can choose a 6 volt alternator in either positive or negative ground. These are big improvements over the old generator and will produce around 50 amps at 6 volts which may be sufficient in a stock vehicle electrical system.

[6 volt alternators](#)

Alternator brackets

Attaching a standard alternators to the engine comes in several types. Make sure to select the correct alternator bracket that will fit your engine application and mounts the alternator so the pulleys line up, most all brackets fit standard deco 10si and CS alternators. [Brackets](#)

Powergen alternators

Powermaster builds the Powergen alternator that looks similar to the original generators made by [Ford, GM and Autolite](#). These are excellent alternator solutions to keep the original look under the hood. These will produce in the 60 to 90 amp range depending on the model and do not require extra

brackets as they are designed to mount to the original generator connection points on the engine. These are 1-wire connections and some come with added post to run dash charge lights making these a great option.

Powergen

There are also some model Powergens that come in 6 volts neg and pos grounds.

Ignition coils

Coils come in various primary resistance depending on the application. The most common primary resistance are .6, 1.5 and 3 ohms. The .6 to 1.5 ohms are typical of 6 volt systems, 1.5 to 3 ohms are typical in 12 volt systems. 1.5 ohms are used in 8 cylinder 12 volt applications and 3 ohms in 4-6 cylinder engines.

There are also oil filled and epoxy filled coils, the difference is epoxy filled can withstand higher vibration and can be installed in any direction, on its side, upside down etc. The oil filled coil should only be installed with the coil tower upright or the coil may start to leak oil if installed on the side or upside down and will overheat.

Most all the automakers used .6 to .7 ohm coils in their 6 volt systems and installed a (ballast resistor) between the ignition switch and coil. The function of this add (ballast resistor) ahead of the coil is to heat up at low engine RPM and reduces the current to the points, as the RPM increases the resistor cools off and increases the current to the points. Most all modern coils are internally ballast resisted within the primary coil winding and do not require the added external resistor.

When converting to 12 volts use 3 ohm coil on 4-6 cylinders and 1.5 ohm on 8 cylinder, these coils will work on both points and electronic ignition systems. Be sure to remove the ballast resistor between the ignition switch and + side of coil in negative grounded systems or the ignitions system will have low spark to the plugs.

Coils are polarity sensitive, in a negative ground system, the negative post goes to the distributor and positive post to the key switch 12 volts. This is opposite from the way a positive ground electrical system is wired and commonly missed in the change over. See coils

Distributor points and condensers

Points and condensers will work fine on 6 or 12 volts systems. There is no need to change them when converting to 12 volts. However, it is always a good idea to replace the condenser often as these oil filled electrical devices can dry out and cause a dead short that will cause the engine ignition system to quit working and a common culprit for engines not to start. Good idea to keep a spare condenser in the glove box.

You can eliminate the points and condenser altogether and keep the original look of the distributor by installing electronic ignition module within the distributor that replaces the old points and condenser. These systems are available for most make and model engine distributors and will make a big difference in engine performance; and the engine will never need to be re-timed again, a huge plus. When selecting the proper electronic ignition module, obtain the distributor part number and use the cross reference guide to find the correct ignitor. [Find your distributor and ignitor here](#)

When changing to any electric ignitions systems the factories all recommend installing low RF (radio frequency wires) because solid core plug wires will cause damage to the electronics and engine misfires. [Plug wires](#)

Gauge reducers

Six volt Oil, Gas the Temp gauges and sending units work only on 6-8 volts maximum. If you apply 12 volts to any 6-volt gauge, it will burn up quickly. We recommend the use of a solid-state voltage reducer rather than any type of resistor because the solid-state devices works the best and protect the gauges. The problem with resistors, when they heat up, the values change and the gauge will not read correctly.

Keep in mind that some auto manufactures used a combination of electric and mechanical gauges while others used all-electric gauges. You will need to select the correct gauge reducer for your vehicle. It is best to use the part number [MGR1](#) for multi-gauge applications and [SGR1](#) for single elec-

tric gauges these are both solid state voltage reducers that regulate the voltage to proper voltage regardless of input voltage.

In most cases, when installing the correct 12-to-6-volt gauge reducer, you do not need to change the sending units because the gauge and sending units will continue to operate on 6 volts. This will save time and expense by keeping the original sending units and gauges. If the polarity is being changed from positive to negative ground, you need to switch the wires on the back of the gauges. If you don't, the gauge will read backwards; nothing bad will happen, just simply reverse the polarity on the back of the gauge.

There is no need to put any reducer on the ammeter or battery gauge as these meters read current flow and are not voltage sensitive as discussed previously.

Starters and solenoids

In most cases the original 6 volt starter will work on 12 volts, and will always turn the same direction if polarity is changed from positive to negative ground. The starter solenoid either the ones on the firewall or on the starter itself should be changed to 12 volts or run the risk of burning up the 6 volt solenoid.

Specially to early Ford flathead starter solenoids that used ground activated start buttons require a 12 volt ground activated solenoid [RL13](#).

If the starter is not working properly on 6 volts, usually will not be any better on 12 volts. You can have the 6 volt starter rebuild to 12 volts or purchase a new 12 volt Hi Torque light weigh starter. Many times it is more economical to buy the new starter and much simpler to install as the solenoids are build into these new starters and weight less than 10 pounds versus the original heavy weight starters with the old external solenoid. [HiTorque Staters](#)

Heater, defroster and wiper motors

When running 6-volt motors on 12 volts will require a resistor to reduce the voltage. Each motor either a [wiper](#) or [heater](#) will require a different and unique resistance value. Be certain you select the correct resistor for the application. When installing resistors, it is best to install in a well-ventilated area under the dash and away from anything flammable or otherwise could be touched because the resistors get warm-to-hot which is perfectly normal.

When checking a resistor for operation, there needs to be a load applied for the resistor to reduce the current. After connecting, turn the motor on and then check the output side of the resistor for lower voltage. When there is no load the voltage will read the same on both sides.

Horns and relay

Horns will generally work fine on 12 volts because the windings in 6-volt horns are heavy gauge wire and appear to hold up with the short duty cycle. The horn will sound a bit different on 12 volts versus 6. There is typically a [horn relay](#) installed in the circuit that needs to be changed to 12 volts. The horn relay is controlled by the horn button should be changed to 12 volts.

Tube radios

If the vehicle has an existing 6-volt tube radio that is to be use, there is a 12-to-6-volt [reducers](#) made specially for older tube type radios. Or have the radio itself converted to 12 volts. If you elect to use a [tube radio voltage reducer](#), make sure to use one that is designed for radios and has correct-size resistors and heat sink. Radios used a vibrator that converted DC to AC internally, these vibrators may need to be changed, just depends on the radio. Radio components and tubes deteriorate overtime and will cause the radio to draw too much current, if this is the case then the voltage from

the reducer will be choked down to less than 6 volt. If this happens may need to change the tubes and other components in inside the radio.

Power seats, window, and convertible-top motors

Seat, window and top motors will run too fast on 12 volts and or damage the device it operates. There are two solutions when converting your vehicle. (1) Rewind the motors, there are several companies that will do this work. (2) find suitable 12 volt replacement motors. At this time we have not found any devices that will adequately reduce the voltage to these motors.

Headlight switch

In older vehicles it is common to find the headlights flickering because of dirty or worn dash switches. Installing a [headlight relay](#) in the light circuit will eliminate this problem and also take the 12-volt current off the switch itself by routing current thru the relay and not the switch contacts itself. There is only one relay required to operate both headlights and simply wired via the Hi-low beam switch.

Wiring harness

As discussed earlier, as long as the existing wiring harness is serviceable and safe to use, the 6 volt wiring will work fine on the new 12 volt system. If the old wiring is missing insulation and coming apart when touched, might be time to rewire the vehicle with a new universal wiring harness that has fused circuits. Wiring harnesses come in different size circuits. Example, the wiper motor would be on one circuit, ignition coil another, headlights another, As you can see it is easy to use up 9-22 circuits fast. [Here is the best in class universal wiring](#), made in USA with great instructions and customer support.

Electric clocks

Electric clocks will need to be converted to 12 volts. There are no voltage reducer solution that will work on electric clocks, mainly do to the many number of clocks and all work a bit different. [Contact the clockworks](#)

Turn signals and flashers

If the vehicle has turn signals and flasher, these need to be changed with a new 12 volt [no-load electronic flasher](#), these new type flashers will never wear our and operate both LED and conventional style bulbs so you can mix and match without any trouble.

Light bulbs

All the old 6 volt light bulbs will need to be replace when converting to 12 volts. The best solution is use the [light bulb finder](#) and order complete sets of light bulbs for the year, make and model. [Click here for the light bulb finder.](#)

Here is a cross reference as well.

Bulb Location	6-Volt Number	12-Volt Replacement
Headlamp	6006 (Sealed beam)	6015
Park w/ turn	1154	198
Park lamp	63	67 or 1155 or 97
Tail and stop	1154	1157 or 198
Tail and turn	1154	1157 or 198
Tail lamp	63	67 or 1155 or 97
Stop lamp	1129	1141 or 1159
Tag light	63	67 or 1155 or 97
Ignition	51	53 or 53x or 1445 or 182
High beam (ind)	51	53 or 53x or 1445 or 182

T/S unit	51	53 or 53x or 1445 or 182
Dash	55	57 or 57x or 1895 or 293
Speedo	55	57 or 57x or 1895 or 293
Clock	63	67 (3 candlepower)
Glove box	55	57 or 57x or 1895 or 293
Dome lamp	88	90 or 94 (6 candlepower)
Courtesy lights	82	90 (6 candlepower)

Battery

Batteries come in all different sizes and cranking amps and is one of the most important components in your vehicle's electrical system. Sometimes we take for granted the battery will always start the engine. This is generally the case, provided the battery has been properly maintained and charged. We think of a 12-volt battery to be fully charged at 12 volts, right? ... Wrong. At 12 volts the battery is only 25% charged. In fact, most starters and starter solenoids will not work if the battery is below 12.4 volts (75% charged) and a low battery can damage the starter and solenoid. A fully charged battery should read 12.6 volts or higher. See chart below

Batteries should always be charged with an external battery charger. Do not use the alternator to charge a low battery, doing this will overheat and damage the alternator's rectifiers and regulator and they will need to be replaced. Internal alternator regulators are generally set at 14.1 to 14.4 volts, the correct voltage to keep the battery fully charged

Battery voltage state of charge:

12.6 + volts 100% charged

12.4 volts 75% charged

12.2 volts 50% charged

12.0 volts 25% charged

11.6 volts Discharged

Battery cables

Condition and size of battery cables is very important to ensure the starter receives adequate current. It is always best to replace the cables when converting to 12 volts. [Order cables](#) with copper connectors and shrink-wrapped ends for long trouble-free service.

Grounds

Older vehicles use the chassis as a means to ground and complete the electrical circuit. Make sure all the grounds are tight and there is a good ground between the engine and the chassis. This by far is the most common electrical problem found in all older vehicles and a primary source for alternators not charging correctly.

Overdrive

Many vehicles built between 1940-1964 used the Borg Warner R10 or R11 electro mechanical overdrives. If you are lucky enough to have one of these overdrives installed and converting to 12 volts, both the solenoid and relay will need to be replaced with 12-volt devices. The wiring, governor and switches will work on 12 volts. [Overdrive electric parts](#)

Need assistance selecting correct parts?

If you need assistance selecting the correct parts to convert your vehicle, let us help you. Simply click the link below, fill out the form and submit, one of our parts professionals will return a complete list of parts for your review.

[Click this link to request conversion parts list](#)

[Complete list of 12 volt conversion kits by make](#)

Installation instructions

The following is a step-by-step instructions for converting most every vehicle to 12 volts. You may need to have a wiring diagram available for your vehicle.

Before starting the conversion, read all these instructions. We also recommend taking a few pictures of the engine compartment and under the dash so you can see how the vehicle is wired. This will help when re-installing the parts.

Start by disconnecting the battery; remove it and place it in a safe place.

Step 1: Locate the voltage regulator, usually found on the firewall. Remove from the regulator the FLD and ARM wires that go to the generator. They are not needed. We recommend leaving the regulator on the firewall this will be easier than removing it and will keep the electrical system intact. The regulator will be inoperative once generator wires are removed. Any new alternator has a built-in regulator and the external regulator is not needed.

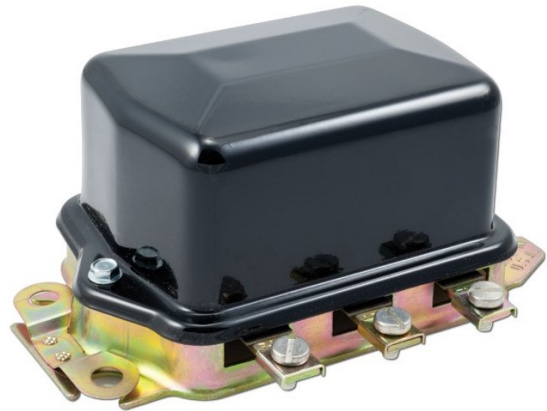

Step 2: Remove the old generator. In some cases, you are removing the existing generator mount bracket, in other applications you will be using the existing engine mount and installing the new alternator bracket. This depends on your specific engine application.

Step 3: Install the new alternator bracket with the hardware provided and mount the alternator to the bracket. The alternator case needs to be grounded all the way back to the negative side of the battery. Make sure the alternator hardware connections are free from grease and dirt to ensure the alternator is properly grounded. If not grounded, the alternator will not charge and damage to the internal regulator may occur. If needed, install a separate 10-8 AWG ground wire from the alternator to the engine and ensure the engine is grounded to the battery.

Step 4: Reinstall the belt and tighten. There should be some belt slack, about 1/2". There is no need to over-tighten the belt, or it will put extra stress on the water pump and alternator bearings. You may need to obtain a new longer or shorter belt, as the alternator set-up maybe different on some engines.

Step 5: The 2-wire alternator requires two electrical connections. Locate the 10AWG RED wire and connect using the provided ring connectors: one end to the alternator output stud, and connect the other end to the + side of the battery via the inline fuse. If you want the dash ammeter or battery gauge to work, you will need to connect the alternator output through the meter and back out to the battery + side. This is only recommended for vehicles with stock electrical systems, high current draw vehicles for example, running AC, radiator fans etc through original meters can cause them to burn up. In these cases recommend installing aftermarket volt meters under the dash.

Step 6: Install the alternator excite plug. The 10Si alternators use a plug with a long white wire that connects to any switched 12-volt power. The easiest connection is the plus side of the coil or it can be installed directly to the key switch at the same place the coil wire is connected. There is a short red wire coming from the plug. Connect this wire to the output of the alternator. CS130 and CS121 alternators only have one long white wire and no red wire and connects same way as the 10Si.



Samples of both 10si and CS130

If installing electronic ignition, we recommend connecting the white excite wire directly to the key switch itself. Sometimes connecting to the plus side of the coil can cause a voltage drop to the electronic ignitor.

Ford 3G alternators commonly found in the Thunderbird conversion kits use a different plug, see wire diagram below. You will see these are wired slightly different.

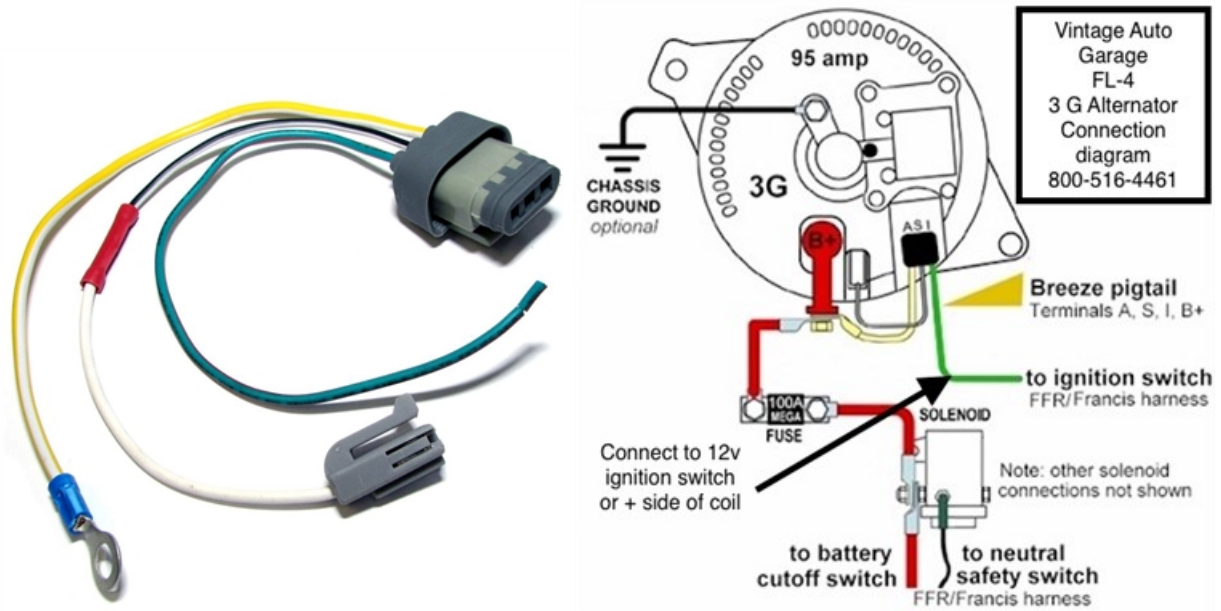

Installing Powegen alternators will have their own set of instructions and should be followed. These are one-wire connection alternators. Some models have the generator light terminal to make it simple to power the dash light. Powergen alternators are designed to deliver current at low RPM and do not require an excite wire. It is very important that these alternators, like the others, are well grounded or the internal regulator will become damaged if started and not grounded also powergen recommends a very tight belt to prevent slippage.

Step 7: Install the new ignition coil and wire the positive side of coil to the key switch 12 volts and the negative to the distributor. Coils are polarity sensitive. Ensure these connections are correct to obtain maximum ignition performance. The coils provided in the Vintage Auto Garage conversion kits do not need ballast resistors, If the vehicle has a ballast resistor under the dash or out on the firewall, remove and wire straight from the key switch to the positive side of the coil.

Step 8: Connect the headlight relay. This may require a specific wire diagram for the vehicle to find the correct wires. This relay removes the high voltage from the headlight switch. The switch itself will work fine on 12 volts once this relay is installed.

Step 9: Replace the horn relay. This can be found generally close to the steering column where the horn button wire extends from the horn button. Connect H= horn, S=horn button, and B=battery voltage.

Step 10: Install the start solenoid. Depending on the make and model vehicle, this could be on the firewall or on the starter itself. If the vehicle has a foot pedal starter, no solenoid is present. Early Fords used start buttons that have one wire and the button goes to ground. The solenoid that is provided is able to connect the same as the original, without the need to rewire the start button. On vehicles with solenoids mounted on the starter, remove the 6-volt solenoid and install the new 12-volt solenoid. In some cases, the plunger that activates the linkage needs to be changed to one that has a bullet end to engage the switch at the end of the solenoid.

Step 10a: 6-volt starters will work fine on 12 volts and will turn in the correct direction when changing polarity to negative ground. Or change the starter to a new modern gear reduction starter available for most make/model year engines.

Step 11: Install the appropriate gauge reducer provided in the kit. Vehicles like Ford and others came with three electric gauges. Chevrolet, GM, and Dodge vehicles came

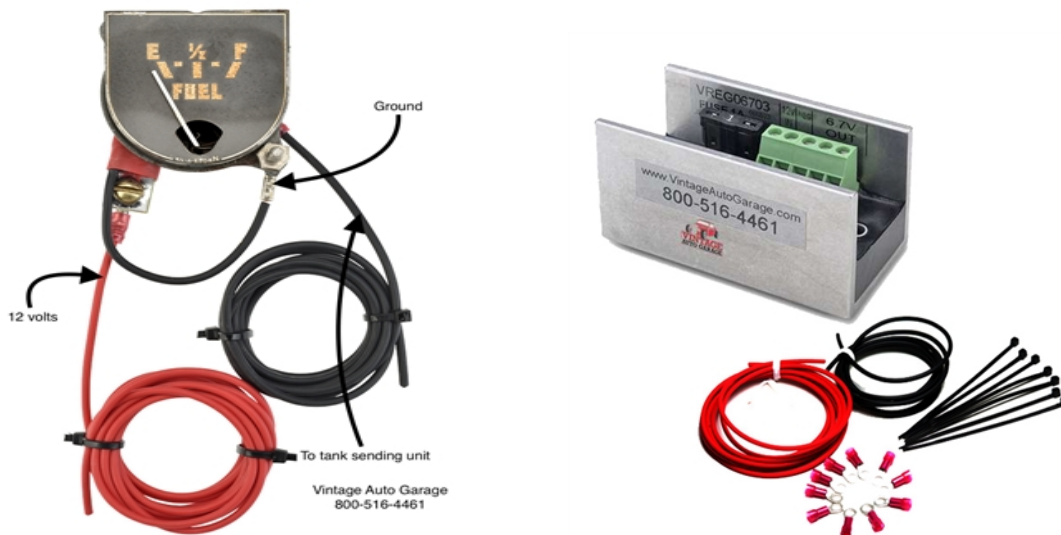

with electric gas gauges and the oil and temp gauge are mechanically operated via a line directly from the engine. Install the gauge-specific reducer/regulator per the instruc-

tions provided with these devices. If converting from positive to negative ground, the wires on the back of the gauges will need to be swapped. If not, the gauges will read backward. The sending units do not need to be replaced because the voltage is reduced to the sending units in addition to the gauges.

Step 12: voltage reducers for the heater, defroster, and wiper motors are installed in the wire from the switch to the motor and can be installed and wired on either end of the reducer. Resistors require mounting to a hard metal surface in a well-ventilated area under the dash for best dispersion of heat. Resistors will get warm-to-hot depending on demand. Resistors work by giving off heat while they reduce voltage. When checking voltage after installing the reducer, the motor needs to be turned on to provide a load, then check voltage on the output side of resistor. If you attempt to check voltage without the motor running, voltage will be the same, at 12 volts, at both ends. Refer to instructions provided.

Step 13: Installation of the radio reducer is similar to motor reducers as they also give off heat when reducing voltage. Mount in well-ventilated area under the dash and connect per instructions provided. The radio will work fine when converting from positive to negative ground. The exception would be if the radio has an electronic vibrator, which is polarity sensitive, then the vibrator would need to be changed.

Step 14: If the vehicle is equipped with a Borg Warner electrically operated R10 or R11 overdrive, the 6-volt solenoid and relay will need to be replaced. part number [ODKIT12](#) for new 12-volt solenoid and relay. The kick throttle switch, governor, and lock-out switch do not need to be replaced; they will work fine on 12 volts.

Step 15: The light bulbs will all need to be changed to 12-volt bulbs; 6-volt bulbs will not work at 12 volts. Most local auto parts store will carry the correct 12-volt bulbs.

Changing your vehicle's polarity from positive to negative ground.

If the vehicle is positive ground, meaning the positive pole of the battery is connected to the chassis and engine, the battery will need to be connected with the negative terminal to ground and positive terminal to starter or starter solenoid. It is very important that, when doing this conversion, the battery is connected with negative ground. Damage will occur to the alternator and solid-state devices if installed with positive ground.

Step 16: Install a new 12-volt high cranking amp battery that will fit the vehicle battery tray. Install new battery cables as needed, positive side to the starter or starter solenoid, negative to the chassis and engine.

Step 17: Before starting the engine, check that the battery is fully charged by an external battery charger. A battery with low voltage will cause problems with the alternator, starter, and starter solenoid. Use the chart below to check your battery. We recommend using a digital volt meter when possible. ***Never try to charge a low or dead battery with the alternator or it will cause damage to the alternator internal regulator.***

Fully charged battery	12.6 volts
75%	12.4 volts
50%	12.2 volts
25%	12.0 volts
Discharged	11.6 volts

Step 18: Starting engine and testing

Be careful to keep fingers, clothing, and hair away from the rotating pulleys ... they can take off fingers!

Start the engine and allow to warm up a few minutes. Raise the engine to 1200-1500 RPM and measure the output of the alternator with a digital volt meter; it should measure 14.1 + / - volts. This is the correct voltage to keep the battery charged at the desired 12.6 volts. Let the engine return to idle and then measure the output voltage to see if it is still 14.1 volts +/- . Alternator output will depend on pulley diameters and engine RPM. If the alternator output voltage is not 14.1 volts +/- , stop the engine and check all connections, there could be a bad ground. If not grounded, connect a separate 10- or 8-gauge wire from the alternator to a good know ground or negative side of the battery.

A quick way to check if the alternator is working, take a pocket knife or screw driver and carefully place on the back of the rear alternator bearing. You should feel a slight magnetic pull, which shows alternator is working and charging and will and stronger pull when more electrical load is applied.

Finally, the wire harness in the vehicle does not need to be changed unless it is not safe. If needed select an aftermarket wire harness that will fit the vehicle.

Trouble shooting guide:

1 Question: The alternator output voltage is the same as the battery voltage when the engine is running or alternator is not charging.

Answer: This can be caused by a bad ground from the alternator case to the negative side of the battery, or the output of the alternator is not connected securely to the + side of the battery or the excite wire is not connected to switched 12 volts. Alternator output voltage, when running, should read 14.1 +/- Make sure the battery is fully charged to 12.6 volts, low battery voltage is common cause for alternators not to charge.

2 Question: Gas gauge is not reading correctly.

Answer: The most common cause of fuel gauge trouble is a poor ground, especially at the tank sender. Make sure all wiring connections are tight and free of dirt and corrosion. A poor ground or loose connection to a fuel gauge system is just like loose or dirty battery cables to your starting system.

3 Question: Going from positive to negative ground and the gauges are reading backward.

Answer: the wires on the back of the gauges need to be reversed.

4 Question: Installed voltage reducer for the heater and it gets very hot.

Answer: The resistors must be mounted on metal / aluminum to dissipate the heat. Some motors will draw more current if they are dirty. Clean the motor commutator and look for worn brushes. This is generally the situation for these reducers to get hot or fail. Remember, to reduce voltage, the byproduct is heat.

5 Question: Ford starter solenoid 7-1013 sticks in the on position,

Answer: This can be caused by a low battery and the starter having a very high amperage demand that put undo current load on the solenoid. Charge battery and the solenoid may need to be replaced.

6 Question: Does the ammeter need to have a voltage reducer?

Answer: No, the ammeter reads current flow between the battery and the electrical system and these gauges are not polarity sensitive.

7 Question: Problems with lights flickering or stop lights not working correctly

Answer: Check all the grounds. Older vehicles use the chassis to run the grounds and the connections can develop rust and corrosion. Trace the ground wiring clean and replace as needed.

8 Question: How to service Vacuum Wiper Motors

Answer: Remove the vacuum wiper hose from the engine manifold and hold it above the height of the dash and squirt brake fluid into the hose. The brake fluid will run down inside of the hose to the inside of the vacuum motor. Reconnect the hose. Turning on the wiper motor with the engine running will circulate the brake fluid inside the vacuum motor and soften the leathers inside of the vacuum motor. Finally, be sure the brass intake screen on top of the vacuum motor is free of dirt and dust. The cause of most vacuum wiper motor failures is lack of use. To revive an old vacuum wiper motor, remove from the car and soak in brake fluid. This may soften the leather bellows inside the motor. Depending on their condition, it might bring them back to life. If the leathers have been dried out for too long and are cracked and separated, you will have to send the vacuum motor to be rebuilt or change to a 12-volt motor.

9 Question: how to solve moisture in distributor caps

Answer: Many vehicles have a problem with moisture collecting inside the distributor cap. The solution is to drill a small, 1/16-inch, hole on the back side of the distributor cap. This will allow air to clear out the moisture. Some of the early distributor caps already came with the hole drilled in the cap.

10 Question: The coil is not producing any spark

Answer: Check that the coil is connected properly, negative side of coil to the distributor and the positive side to the ignition switch 12 volts. It is common that this is missed when removing and re-installing the new coil.

11 Question: do the turn signal switch and flasher need changing?

Answer: the turn signals switch will work on 12 volts. The 6-volt signal bulb and the flasher will both need to be changed,

If you need assistance with your installation, call 800-516-4461 **or send message**
[here](#)

Enjoy your new 12-volt electrical system.

[Vintage Auto Garage](#)

800-516-4461